



# The Multisensor

May 2015

Competence through Innovation and Experience

65 Years Optics

25 Years Multisensor Technology

10 Years Computed Tomography

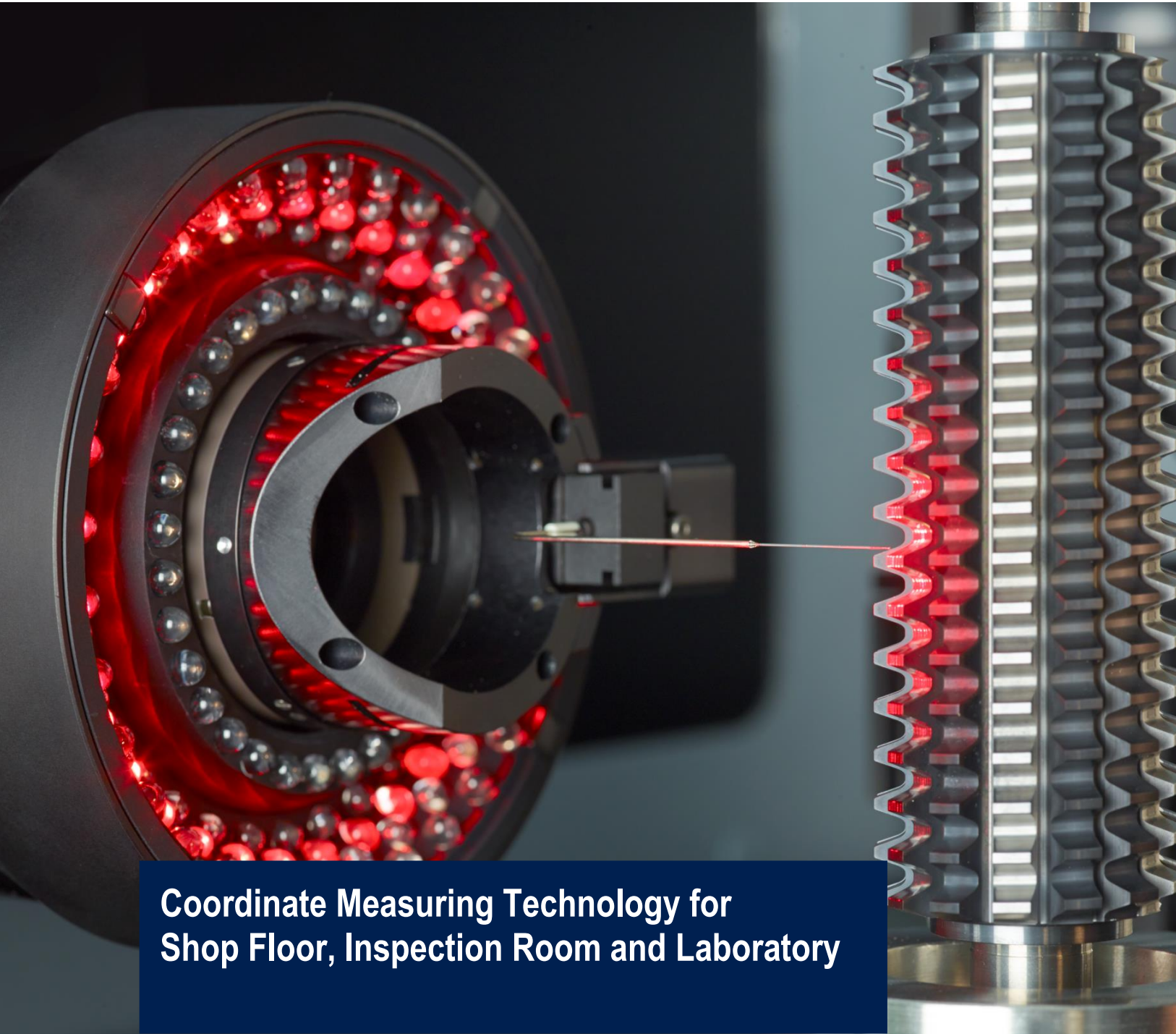

Coordinate Measuring Technology for  
Shop Floor, Inspection Room and Laboratory

*Title: WFP/S Werth Fiber Probe on the WMS Magnetic Interface  
Standardised hobbing cutter measurement with the patented Werth Fiber  
Probe WFP/S with Werth Magnetic Interface WMS for automatic exchange  
between diverse optical and tactile sensors*



## Competence through Innovation and Experience

This edition of our newsletter "The Multisensor" – in a new format – brings you more information about the technology and application of Werth coordinate measuring machines. The subject matter is centered on our anniversaries: 65 years of optics, 25 years of multisensor technology, and 10 years of X-ray tomography in coordinate measuring technology. These points also mirror our product highlights for 2015.

The Werth QuickInspect MT is a modern successor to profile projectors and expands the measurement range and resolution limits of previous "in image" measuring machines with the patented "Raster Scanning" and "OnTheFly" functionality. A special version of the WinWerth® software package ensures that these machines are very easy to operate.

The general development target of our WinWerth® measurement software in this year's new Version 8.35 is simplified operation. New functions for editing and testing, for report design, and for semi-automated measurement with various sensors will make work easier for both inexperienced and experienced users.

The range of machines with multi ram solutions for ergonomic measurement with multisensors has been extended to include machines for larger workpieces, such as the Werth VideoCheck® HA, with a measurement range of 1000 mm x 2000 mm x 800 mm (accompanying image). With our innovative multisensor concept, this machine can combine the SP80 tactile sensor as an alternative to a rotating/tilting SP25 scanning probe on the first ram, and optical multisensors and the Werth Fiber Probe on the second ram.

The new version of the Werth Fiber Probe has an interface that is compatible with many other sensors. This multisensor solution has the advantage that conventional probes, the contour sensor, the fiber probe, and the laser distance sensor can be used with or in front of the optical beam path. This improves ergonomics and allows the entire measurement range of the machine to be used.

A series of new functions for tomography coordinate measuring machines in the TomoScope® and TomoCheck® series round off our 2015 "spring offensive". We will continue to concentrate on developing good ideas in order to provide our customers with a technical competitive advantage.



Dr. Ralf Christoph  
President and Owner  
Werth Messtechnik GmbH

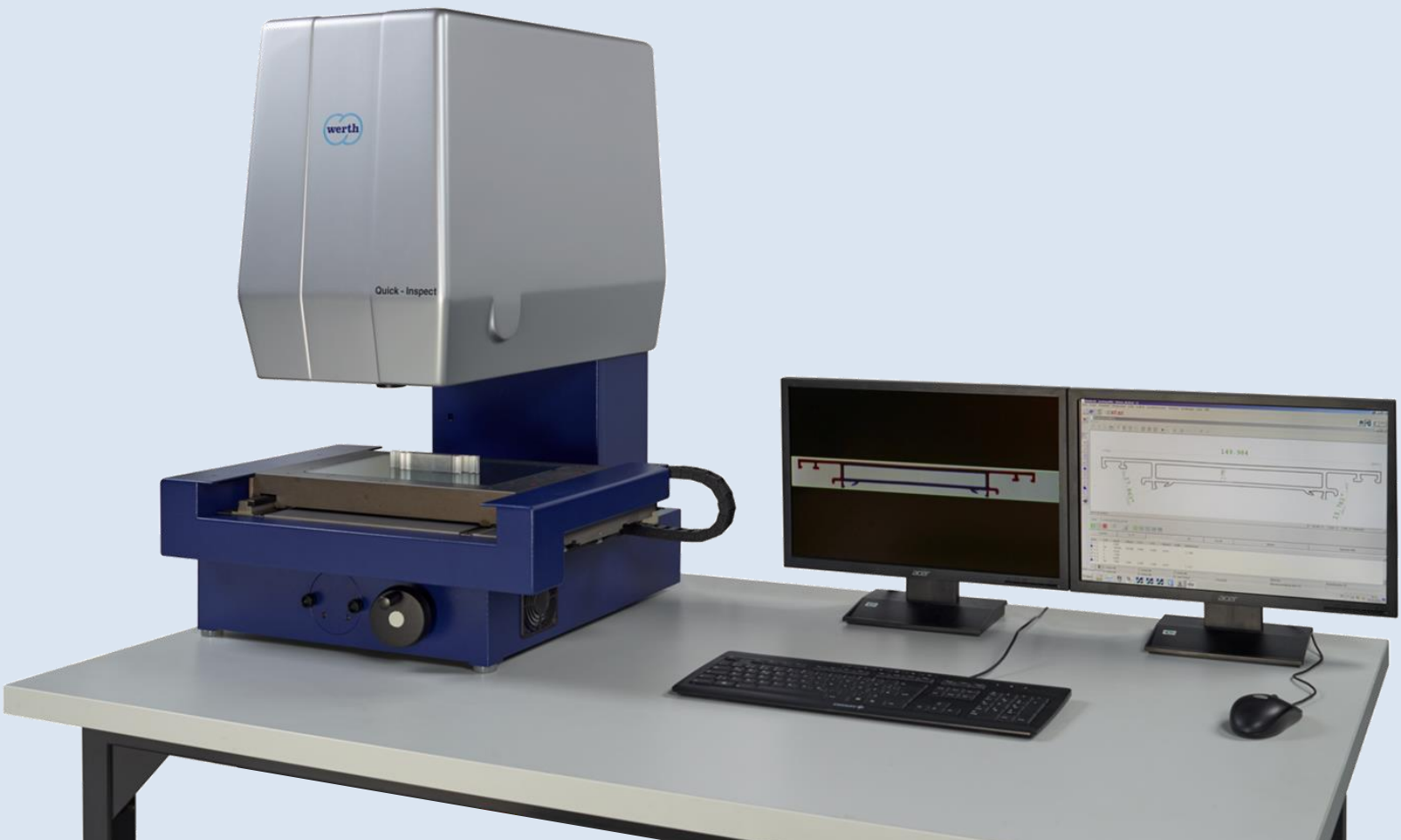

## Contents

<b>Competence through Innovation and Experience</b>	<b>2</b>	<b>Werth Fiber Probe WFP/S</b>	<b>13</b>
	3	Full Integration in the Werth WMS	
<b>Contents</b>	<b>4</b>	Magnetic Interface Concept	
WinWerth® 8.35	5	<b>Computed Tomography</b>	
<b>Edit Measurement Programs Step by Step</b>		Analyzing Volume Data with Avizo	
<b>in TeachEdit Mode</b>			
WinWerth® 8.35		<b>Werth 3D-Patch</b>	<b>14</b>
<b>Flexible Office-style Report Design</b>		Surface measurement with Focus Variation	
WinWerth® 8.35	6	<b>Werth China is Moving</b>	<b>15</b>
<b>Expanded Point Distribution Modes for Multisensors</b>		Expansion in the USA	
<b>Werth QuickInspect MT</b>	<b>7</b>	<b>New Demo and Service Center in Italy</b>	
<b>Developing a Comprehensive Metrology</b>	<b>8</b>	Expansion of the Giessen Location	
<b>Standard with CMM</b>	<b>9</b>		
Application Report	<b>10</b>	<b>Multisensors in Quality Assurance at</b>	<b>16</b>
	<b>11</b>	<b>Kleiner Stanztechnik</b>	<b>17</b>
<b>VideoCheck® Fixed Bridge Machines</b>	<b>12</b>	Application Report	<b>18</b>
			<b>19</b>
		<b>Credits</b>	<b>20</b>
		<b>Newsticker</b>	

*Above: Measurement „At a Glance“*

*Werth QuickInspect MT with Custom Measurement Range*

## WinWerth® 8.35

### Edit Measurement Programs Step by Step in TeachEdit Mode

New easy-to-use stepping and testing functions have been integrated into WinWerth®'s TeachEdit mode. This replaces the former Autostep mode. The measurement program to be edited can be started at any point by marking the Feature Tree, or any part of the program can be run as desired. It is also possible to use only parts of an existing program to measure selected features. Individual elements can also be selected and measured automatically, for example to evaluate modifications. Because the alignment from a preliminary measurement can be re-run, it is possible to test various workpieces. By re-running a local alignment, the effects on the measurement result can be tested, or expanded with additional dimensions. Subroutines and loops can also be run individually after teaching them. This places their results in the Feature Tree and the graphic, so they are available to be linked by means of computational operations.

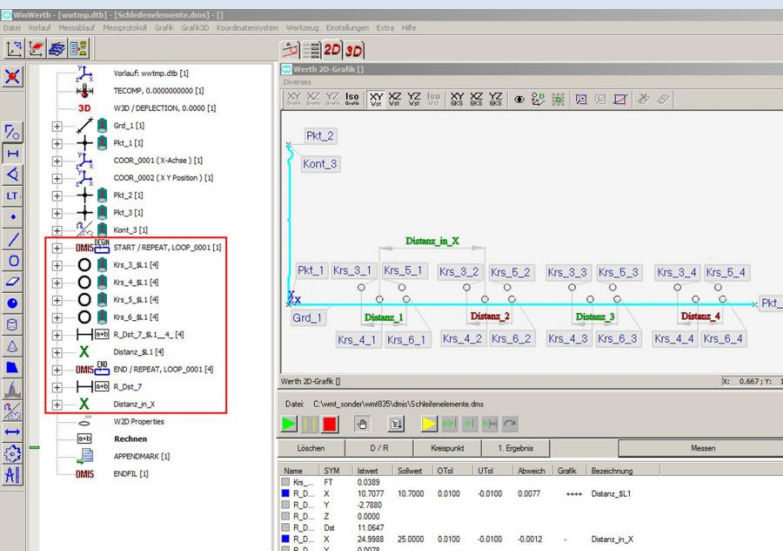

Loop elements in the 2D graphics window

## WinWerth® 8.35

### Flexible Office-style Report Design

Measurement results from a wide range of WinWerth® software modules, such as tables of measured values, 2D and 3D plots, and BestFit or tool measurement program plots can now be documented in a uniform measurement report in any sequence and format.

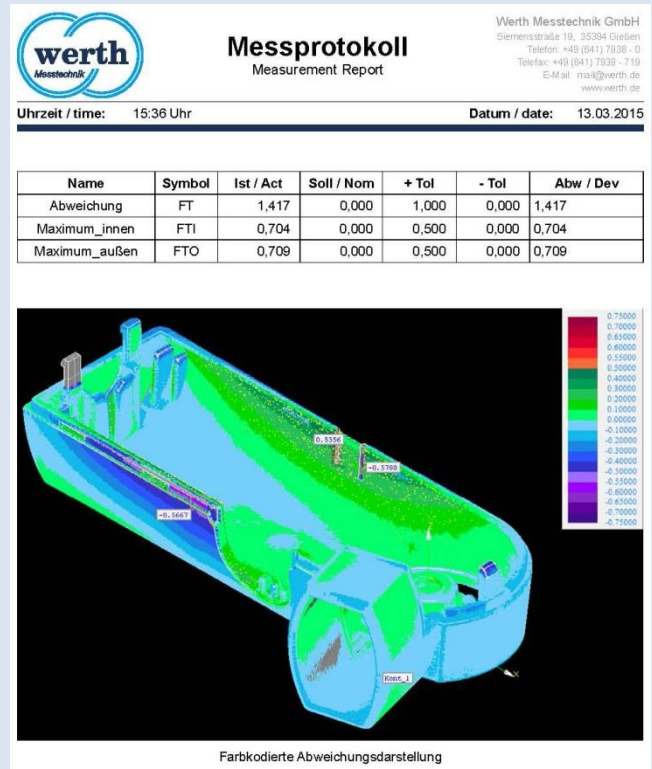

Measurement report with table of features, image, and caption

Customer or application specific templates for the report header are selected in the "Measurement report" menu. WinWerth® user administration recognizes the username and automatically adds the operator's information to the report header. The report header data can also be input automatically with a barcode scanner.

The measurement report can contain any desired graphic image file with a caption and can be formatted to suit the user's requirements. Image captions are inserted as a comment via the "Tools" menu.

For repeated measurements, the report contents are updated for each cycle while maintaining the underlying format. They can then be saved or printed.

## WinWerth® 8.35

### Expanded Point Distribution Modes for Multisensors

The point distribution function allows interactive, automated measurement of geometric elements. The software automatically distributes the measurement points or scan lines across the selected geometric elements. As before, the geometric element can be input by selecting it on the CAD model, or by interactively measuring the minimum number of points to define the geometric element. In addition, this can also now be defined in the "Point distribution" tool by entering parameters.

In the expert dialog, the range over which the measurement points are distributed on the template element can also be defined. The 3D graphics window can show a preview with various types of representation. The standard shows the travel paths of the sensor, including the probe sphere, the contact vectors and the measurement points. All simulations can also be shown individually or in any desired combination; for example, the travel paths only can be selected to make the image clearer when there are a large number of measurement points. All tools for operation are included in a single, clearly arranged software window.

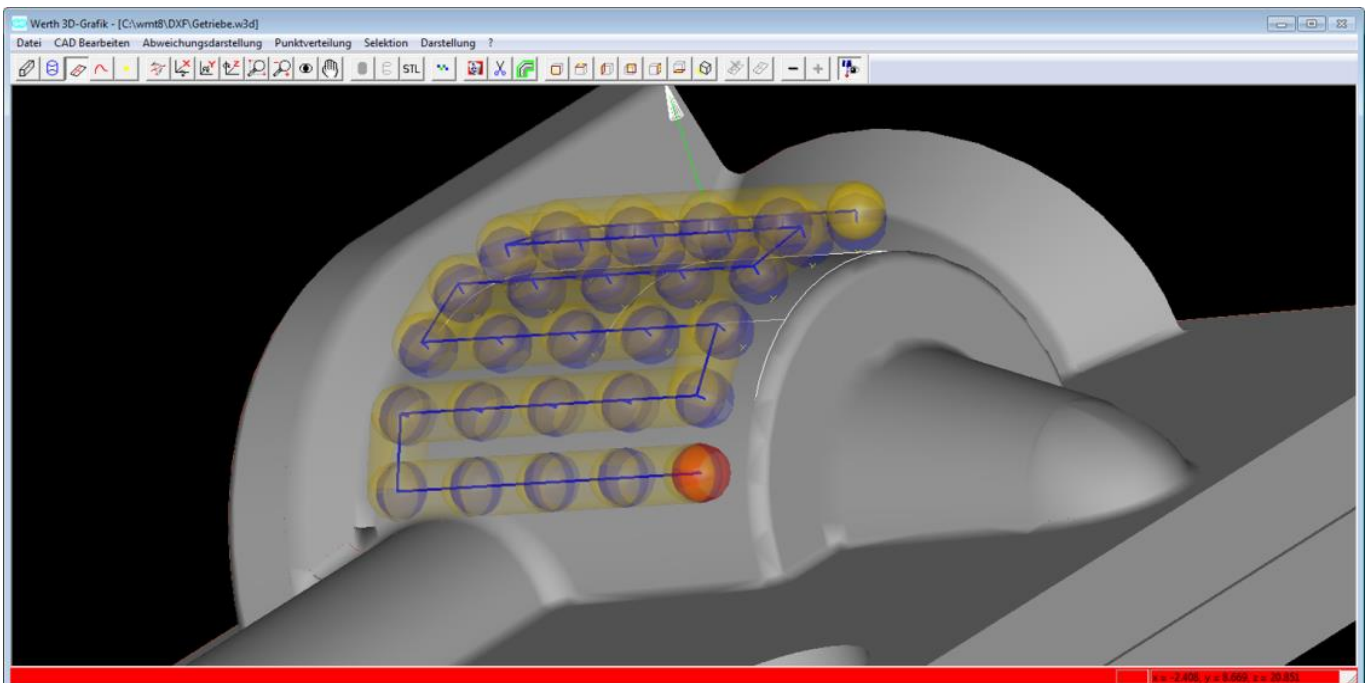

In the new version, the number of available strategies for distributing the paths or points has been greatly expanded. The user can select from a wide range of strategies. For planes, the selection includes raster, polyline, circle, or star. For cylinders, it includes circles, surface lines, or helical distributions. For the sphere and torus elements, circles or stars are available. The selected strategy is shown as a preview in the "Point distribution" tool. For each strategy, either the quantity or spacing of both the paths and the measurement points on each path can be adjusted.

#### *Surface lines on a cylinder*

The new version of automatic point distribution is available for all sensors. For conventional measuring probes, the WFP/S and 3D-WFP Werth Fiber Probes, the WLP, WCP, CFP, LLP distance sensors and Autofocus measurement can be done in both single point and scanning mode. Analogous point distribution modes are available for the image processing sensor for measuring circles, lines and curves.

## Measurement "At a Glance"

### Werth QuickInspect MT with Custom Measurement Range

Capturing an entire workpiece in one image ensures easy operation and short measurement times. For smaller workpieces, the measuring machine acts like a classical profile projector and uses the field of view of the optics as the measurement range. This principle has been implemented for various measurement ranges in the classical QuickInspect machines (on the left). For larger measurement ranges, the resolution and thus the precision of measurement is limited by the number and size of pixels.

objects (up to 250 mm length as standard) can be visualized and accurately measured. In automatic mode, the measured object is detected fully automatically after raster scanning and the matching CNC measurement program is started.

To ensure comparability to conventional coordinate measuring machines, the machines are specified to ISO 10360 and VDI/VDE 2617 and are traceable to the length standard of the German National Metrology Institute. Depending on the optics selected, measurement deviations of fractions of a micron or a few microns can be achieved. For most QuickInspect models (0.037x to about 1x), it is no longer necessary to adjust the focus, due to the telecentric configuration.

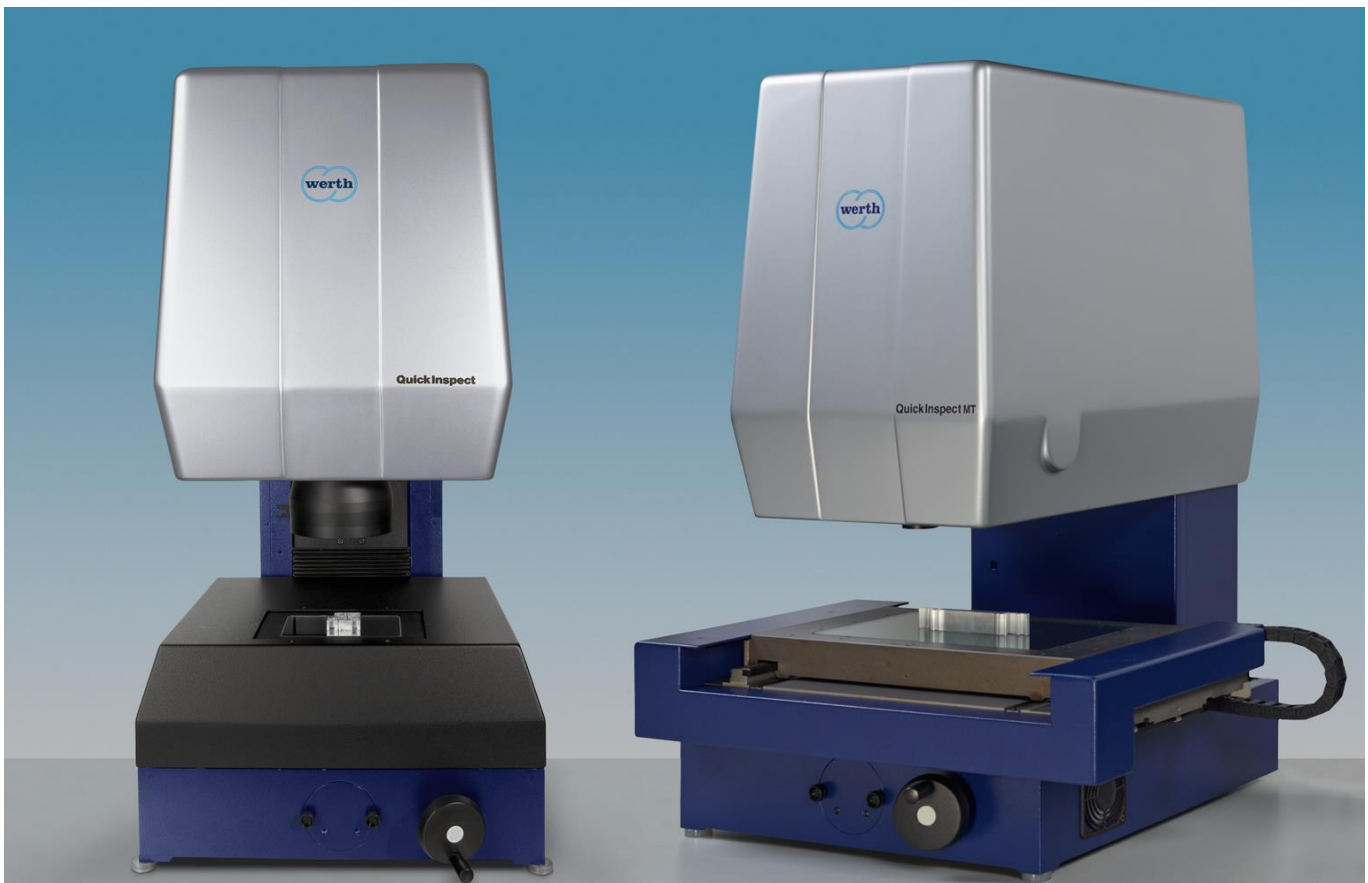

For greater requirements of the measurement range, resolution, and measurement uncertainty, the same ease of operation is implemented with the new QuickInspect MT (on the right) with measurement "in the image". To do so, the machine raster scans workpieces in seconds "OnTheFly" at the push of a button. This produces high-resolution images with nearly any number of pixels and high precision (patent). Even especially small or high-precision features on larger

#### *Werth QuickInspect and QuickInspect MT250 2D-CNC*

For high magnification, setting the focus is simple with an easy-to-use focus function in the image processing software. This shows the user the position at which the workpiece is focused to produce the optimal conditions for measuring. Temperature compensation is also integrated for measurements in the manufacturing environment.

## Good connections

### Developing a Comprehensive Metrology Standard with CMM



*The Weidmüller company, specializing in technical connectors, is interested in shifting from manual to automated operator self-checks. The company has therefore recently developed a standard for geometric measurement tasks and analysis on the basis of a 3D multisensor coordinate measuring machine from Werth*

*Messtechnik, Giessen. This provides the precise, reproducible measurement results from the lab to series production.*

No industrial sector today can do without electronics and electrical connectors (known as "Industrial Connectivity"). Industrial connectors are used to transmit the three basic elements of energy, signals, and data. One provider in this sector is the Weidmüller company, based in Detmold. Making perfect connections possible is one of the main areas of focus at this traditional company. Weidmüller requires the highest level of quality assurance, starting with quality management based on ISO 9000 and extending to continuous monitoring by independent institutions that audit production locations as well as quality management and the company's in-house lab facilities.

The essential basis for high quality products is provided by the employees with the quality philosophy firmly ingrained in their consciousness. Olaf Despang, manager for test equipment, says, "Weidmüller has grown large based on quality. This means that every employee, not just the metrology techs, carry responsibility. One of my department's responsibilities is to ensure that quality assurance is correctly structured and that optimal measuring equipment is available."





*Filigree and sensitive components present a great challenge to metrology. Its precision and available measurement methods make the Werth ScopeCheck the ideal solution.*

## Future-proof Metrology

Because the products are becoming ever more intricate and complex, these factors must be checked and optimized on a continuous basis. One of Olaf Despang's group has been assigned the task of ensuring that the metrology used at Weidmüller is future-proof. "Our structure is set up with what we call quality stations in individual production areas, in addition to a central

metrology lab. The workers themselves are also responsible for measurements taken during the manufacturing process," explains Despang. "Previously, each station had a different measurement philosophy and different equipment. We are now in the process of standardizing them." "In the future, the measurement departments and production areas should be compatible, so that products with prototype and pre-production status can be handed off to mass production complete with measurement programs and fixtures.

Many discussions with the participants and related investigations indicated that a common basis for the measuring equipment was indispensable. To reliably handle various measurement tasks, the responsible parties decided on coordinate measuring technology with multisensor capabilities. Weidmüller selected Werth Messtechnik GmbH, Giessen, as its partner for 3D coordinate measuring machines.

An extensive market analysis was performed prior to the purchase of the new measurement equipment. All our quality centers helped to develop the specification and jointly defined the requirements for functionality, precision, and measurement range. Olaf Despang summarizes, "We looked very meticulously at various providers and ultimately selected Werth. Our previous experience certainly played a role in this decision. Werth has been represented with a VideoCheck measuring machine in our central measurement lab in Detmold for several years." The high level of measurement accuracy that this machine features is used to measure individual components and initial samples. International service was also cited as a very important factor. If such machines are used at an overseas production location in the future, then the manufacturer will need to provide the same level of support there as it does in Germany. In recent months, Werth has shipped several ScopeCheck machines to Weidmüller. They are located close to the production line at various quality stations.



*Measuring the flatness of plastic sheets. The laser on the 3D multisensor coordinate measuring machine reduces the inspection time by about two-thirds.*

The ScopeCheck S is a 3D CNC multisensor coordinate measuring machine designed for near-production measurement, covering a measurement ranges of X = 200, 300, or 400 mm, Y = 200 mm, and Z= 200 mm, depending on the configuration. Weidmüller ordered the machines with three different sensors: the Werth image processing sensor, laser sensor, and touch probe systems. The laser sensor is intelligently integrated in the image processing beam path of the machine, so that there is no loss of measurement range when

taking combined measurements. The patented Werth Zoom function with MultiRing illumination ensures high contrast images of the features being measured. When required, the working distance can even be changed to measure features at a great depth without colliding with the part, or to obtain a particularly flat angle of illumination.

One of the 3D multisensor coordinate measuring machines is located at the quality station managed by Rosario Orovero, the quality assurance group leader for "New Products". This department produces the initial small series for newly developed products, which will later be handed off to series or mass production. The primary task is to measure components produced at Weidmüller for classic connectors, such as pass-through terminal blocks. These primarily include small, delicate plastic injection molded and stamped parts, with surfaces, radii, and angles that can be very difficult to measure.

Rosario Orovero describes their rapidly advancing product development: "Our terminal blocks used to be larger, with fewer functions. Then it was enough to measure the length, width, and height of a part. Today, electrical enclosures are designed to fit as much as possible into a small area, so our products are changing." A terminal block may be about the same size today as it used to be, but it has over ten times the functionality. Contacts and blades are so fine that the use of profile projectors, dial indicators, and other manual measuring equipment is no longer sufficient, even for production monitoring. The trend is therefore moving toward combined optical, tactile, and laser based measurement solutions, such as provided by the Werth ScopeCheck multisensor machine.



*For tactile measurements, the components must be properly clamped to prevent them from moving. The fixtures are later used for process control in production as well.*

The fine components need to meet tolerances that can be as small as  $\pm 20 \mu\text{m}$ . This requires the measuring machine to have a precision range of no greater than  $2 \mu\text{m}$ . Rosario Orovero confirms: "The ScopeCheck meets this specification, which is needed for our products. Werth has even more precise machines available in the VideoCheck series, but they would have been overqualified for our production area application."

## Shorter Inspection Times

The 3D multisensor coordinate measuring machine also has many benefits for measurement tasks at the quality station, such as measuring the flatness of large plastic sheets. "Previously we took care of these with a dedicated optical machine," explains Rosario Orovero, "where we had to set the focus at various points and then relate them to each other. This took about two minutes. On the ScopeCheck, we use the laser, and it now takes only about 40 seconds. For a single part, that is not very critical. But if process capability needs to be analyzed and measurements taken on over 50 parts, then the time adds up."

Multisensor capability is important for Orovero's team in any case. This quality station runs all new products on the machine, so it needs to be flexible enough for any measurement task. Rosario Orovero points out that any time savings is critical in this phase of development. "The products have to go to series production as quickly as possible in order to gain an advantage in the market. With our ScopeCheck multisensor measuring machine, we can now measure many parts at once in a single setup, which was previously impossible. This also saves time and money, and generates the information that we need in order to control production."

The metrologists thus combine modern probe methods for capturing component geometry and control the automated measurement sequences using the Win-Werth software package. This produces traceable and reproducible results. "With the multisensor concept, we can combine all of the measurements taken on one or more components within the software – basically at the push of a button. Operator and data entry errors are nearly impossible," says the metrologist happily. Documentation is also easier than before. An interface has been installed at Weidmüller for the measurement

results to be transferred to their SAP system directly with no errors or loss of data.

To provide the production areas with the same high quality measurements as Orovero's measurement lab, additional Werth measuring machines will soon be located near the stamping and bending press and the injection molding machines. The stated goal is to get away from manual inspections, replacing them with automated solutions. Therefore, the quality headquarter will provide to production the entire measurement. "Our colleagues at the production sites receive from us a USB stick with measurement programs and the fixture that we have already built. This means that they only need to make minimal adjustments on site, and the programs can run just as they are – fully automatically."



*Experts for measuring technology and quality assurance in a discussion – Rosario Orovero (left) and Olaf Despang agree: "Based on the Werth 3D multisensor coordinate measuring machine ScopeCheck, we are establishing a standard for inspection equipment which offers real benefits for the future."*

This helps the operators, who are specialized in their own processes, but are not metrologists. The pre-fabbed measurement programs mean that the same measurement points are captured in the same way, producing reliable and reproducible measurement results. The operator also gets the green light for continuing production sooner than with previous methods. Even if the last step in production has not yet been completed, Olaf Despang and Rosario Orovero agree that they are on the right path: "The ScopeCheck machines are perfectly suited for our intended use, and our work with the Werth company has developed into a true partnership. Their service is great and we are convinced that we will continue to find more future-proof metrology solutions together."

## VideoCheck® Fixed Bridge Machines

### Dual Ram Now Available for HA Versions of Large Measurement Ranges

The Werth VideoCheck® FB, with a fixed bridge and dual ram, is now available in an HA version for larger measurement range (image page 2). The multisensor coordinate measuring machine has a measurement range up to 1000 mm x 2000 mm x 800 mm (X,Y,Z). The construction principle provides a double benefit. The shorter span in the X direction means that the bridge is shorter and thus more stable. The machine is also easily accessible and can be loaded from four sides. The proven dual ram concept is used primarily for large workpieces and with a rotary / tilt axis to avoid collisions.

The Werth VideoCheck® FB HA is specified comparable to ISO 10360 and VDI/VDE 2617. Under good measurement lab conditions, the maximum permissible error, MPE E, is  $(0.95 + L / 600) \mu\text{m}$  using the SP80 probe system. The granite table with air bearings can maintain the specified maximum permissible error while supporting up to 100 kg, or optionally up to 250 kg. For measurements on especially heavy workpieces, it is possible to remove the transmitted light unit.

The two ceramic rams can be equipped with a wide range of sensors. For example, the SP80 tactile sensor and a rotary / tilt PH10 head with the SP25 probe may be exchanged on the same ram, while the second ram is equipped with optical and tactile-optical sensors.



*Dual ram with tactile, optical and tactile-optical sensors*

## Werth Fiber Probe WFP/S

### Full Integration in the Werth WMS Magnetic Interface Concept

The Werth WMS magnetic interface is a universal exchange interface for diverse sensors such as conventional mechanical probes, the WCP Werth Contour Probe, lens attachments and angular optics.

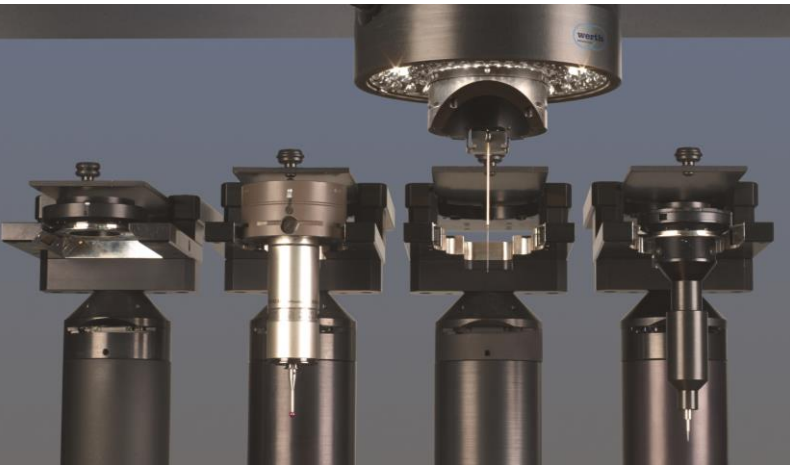

*WFP/S Werth Fiber Probe on the WMS magnetic interface, with other sensors in the background*

The loss of measurement range when using multiple sensors, due to the offset between the sensors, is now a thing of the past. This multi-sensor interface is now available for the WFP Werth Fiber Probe as well. The new WFP modules, specially developed for the WMS, are available for both the Werth Zoom and for telecentric optics. They can be exchanged fully automatically via a parking station. The purchase of a fiber probe includes two modules with one fiber each. Stylus tips that have been pre-aligned at the factory are available upon request.

## Computed Tomography

### Analyzing Volume Data with Avizo

*TomoScope® and TomoCheck® coordinate measuring machines are often used for qualitative analysis of the structure of workpieces, in addition to measurement tasks.*

Avizo 3D volume analysis software is an effective solution for analyzing data from computed tomography. For example, blowholes and glass fibers can be analyzed, assemblies made of multiple materials can be segmented, wall thicknesses can be measured, and the measured volume can be animated in various rotational orientations. Procurement costs for Avizo are relatively low. Because the complete package already includes full functionality, the cost is only one-fifth that of comparable software solutions. Avizo can also be adapted by the user to suit their applications by macros that can generate application specific sequences. Avizo has very powerful filter functions that can increase contrast, improve focus, or smooth out the entire volume. Virtual disassembly of components is also supported, along with sectional views that cut through the volume.

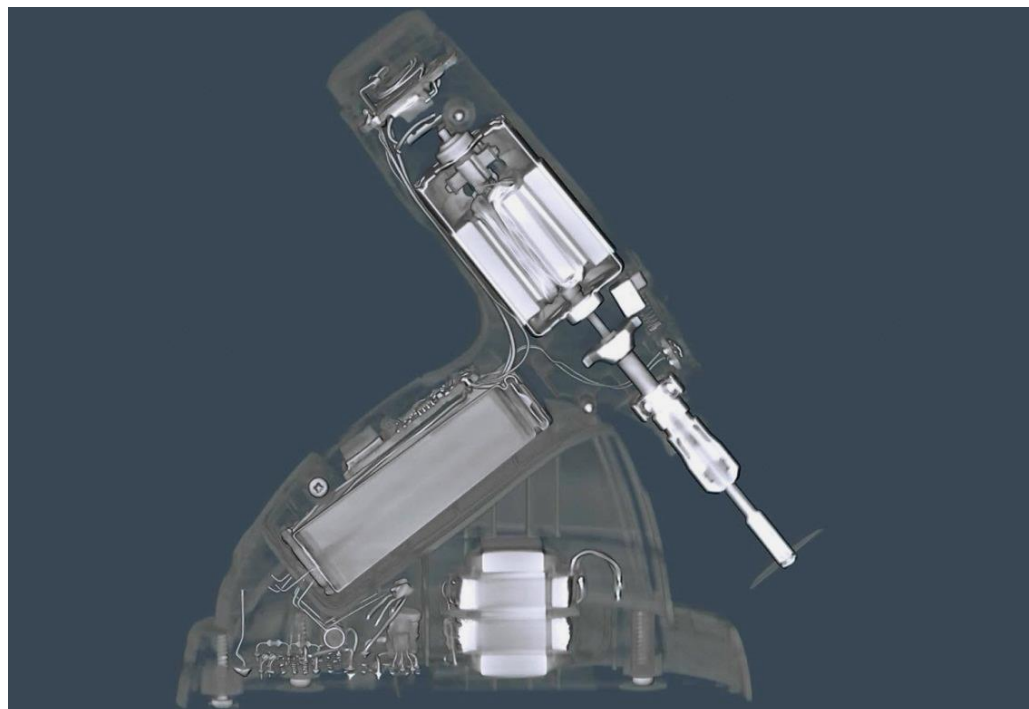

*Sectional cut through a multifunctional tool*

## Werth 3D-Patch

### Surface measurement with Focus Variation – HDR Increases Performance

The 3D-Patch/S is available for all Werth Messtechnik coordinate measuring machines, including retrofitting of existing machines. A new, automatic light control algorithm adjusts the intensity of illumination automatically to the workpiece surface. The parameters of the measurement, such as the focal path and speed, as well as the filter method for the point cloud, can be easily adjusted by the operator using WinWerth®.

If the area to be measured is greater than the field of vision at the magnification selected, then several 3D-Patches can be arranged and the individual measurement fields can be merged together into one overall surface.

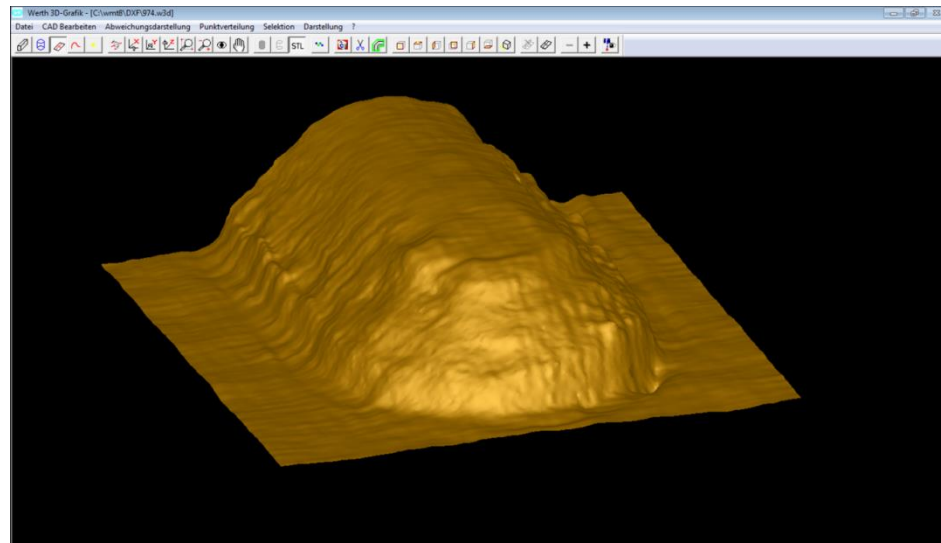

Point cloud in STL format measured with 3D-Patch/HA

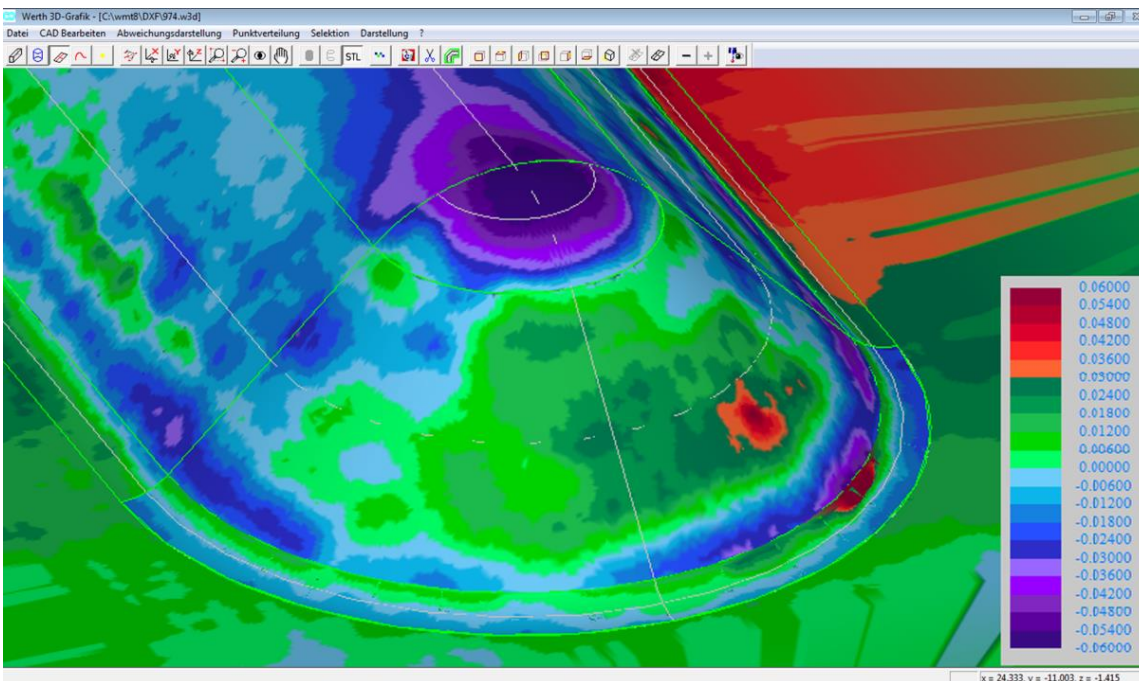

Deviation between CAD model and point cloud measured with 3D-Patch/HA (color-coded)

The new 3D-Patch/HA also allows the use of a High Dynamic Range (HDR) function. The dynamic range of the images is significantly increased by using different

exposure times and just using the best information to compute the point cloud. In this manner, even heterogeneous surfaces with great variation in brightness can be captured reliably. Examples of this include when different materials are present or slope angles vary greatly within the measurement area. High-performance filters are

available for the 3D-Patch/HA to ensure that even "uncooperative" objects can be measured reliably. The 3D-Patch/HA feature requires the Werth HiCam (delivery date after or in 2011). A high-performance special graphics processor is recommended. This graphics processor speeds up data processing, especially with large stacks of images (HDR) and filter functions.

## Werth China is Moving

In March 2015 Werth China has moved into a new, larger office and showroom facility in the Nanopolis high-tech park in Suzhou. The move provides greater customer proximity in an excellent traffic location, with connections to international airports in Shanghai and Wuxi. The experienced team led by Dr. Li is your expert partner for any questions about Werth Messtechnik GmbH products and services.



*New Werth China company headquarters in the Nanopolis high-tech park*



*Tina Silva at the new demonstration facility*

## Expansion in the USA

In June 2014 Werth Inc. established a branch office in Morgan Hill, California, close to the Silicon Valley. Sales Manager Ken Kino, Application and Service Engineer Florian Herzog and assistant Tina Silva look forward to efficiently supporting our customers on the West Coast.



*Werth Italia sales and service center*

## New Demo and Service Center in Italy

Since October 2014 the new sales and service center of Werth Italia s.r.l. is located in Gallarate, near the Milan Malpensa airport. The scope of services that Werth Italia s.r.l. provides includes product advice, user training, service measurements and machine demonstrations as well as warranty services.

## Expansion of the Giessen Location

To make room for our company to continue to grow, construction work has begun on about 1000 m<sup>2</sup> of additional modern office space. Construction has also started on a new logistics center that will meet the rising requirements for shipping high-precision coordinate measuring machines.



*Construction site at the Giessen location*

# When Optical Sensors Work Hand in Hand

## Multisensors in Quality Assurance at Kleiner Stanztechnik

*Kleiner Stanztechnik designs and manufactures their own tools that they need to produce precision stamped parts. This makes a significant difference in the quality of the components produced. The high precision Werth Video Check HA multisensor measuring machine — using different optical sensors selected to match the measurement task — provides precise measurement results for the three-dimensional shape of the tools and components.*

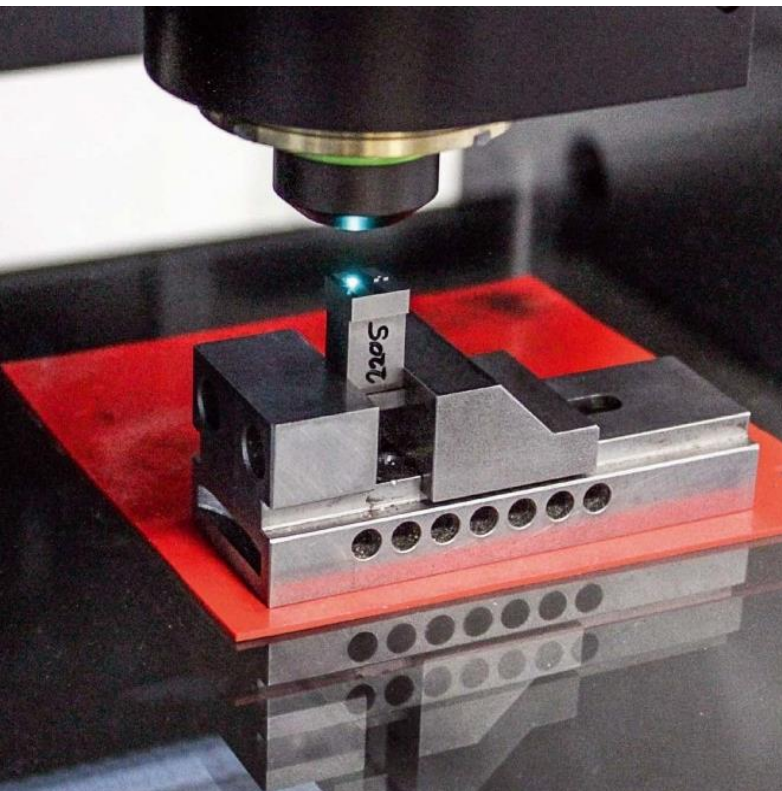

*Measuring an embossing die with a Nano Focus Probe*

Microstamped components, springs, snap panels and even populated stamped mesh parts—Kleiner GmbH, headquartered in Pforzheim, specializes in these precision stamped components which are used in many industries such as automotive, plastics, electrical, medical and electronics. The company orients itself to the needs of its customers with the motto: "Quality is what the customer wants." Because the quality of manufactured components is largely determined by the precision of the tooling and because quality does not happen by chance, the certified punched component specialist has set up a high performance tool shop and advance quality planning.

Jürgen Fässler has been part of the advance quality planning team since 2006. In addition to an education as a toolmaker, he collected over 20 years of wide-ranging experience in metrology and test engineering. He explains: "We serve as an interface between quality assurance and the departments that are in contact with customers. My duties include supporting quality related issues for new projects from customer coordination to series production launch." This also includes planning, designing, and selecting measurement and testing equipment.

He is particularly keen on this task when it affects the tool shop. Metrology plays a critical role there, as he explains: "We want to detect any deviations from the specifications as early as possible, and not just once the tool is online and ready to be run. Therefore, we check the

shape of electrode, punch and die inserts very carefully while they are being manufactured."

This is exactly the reason why Kleiner invested in a high precision 3D multisensor measuring machine.



*Jürgen Fässler (left) from advance quality planning at Kleiner discusses an example of the use of multisensors with Detlef Ferger, Sales Manager at Werth Messtechnik*



## Multisensor Technology for Complex Three Dimensional Measurement Tasks

The responsible team searched over a year for a suitable solution, had test measurements made, performed analyses and compared various models in terms of flexibility, precision, and operator interface software. "At Werth Messtechnik we finally found what we needed for our tasks in the tool shop with the VideoCheck HA 3D multisensor coordinate measuring machine. Above all, the precision and variety of sensors that can be used make it possible to perform our often complex three dimensional measurement tasks flexibly," Fässler explains. "We find the optical Nano Focus Probe NFP and Werth Fiber Probe WFP, which work hand in hand, to be especially useful. They make it possible to very carefully measure three dimensional surfaces of small punches, dies and die inserts as well as EDM electrodes in a single process step within a short time. Sensors offered by other providers cannot keep up."

### Proven Partnership with Werth Messtechnik

The employees at Kleiner have long been familiar with Werth measuring machines. They are still very satisfied with their first measuring machine, a Werth Inspector, purchased in the 1990s. The OS department, which now has twelve employees, has therefore purchased additional Werth measuring machines over the years for measuring and inspecting components and tools. That includes a FlatScope, a ScopeCheck and two VideoCheck machines.

The new VideoCheck HA 400, with a measurement range of 400 mm x 400 mm x 200 mm, is located in the tool shop. The tolerances on tools and tool components are in the micron range; on the stamped components they are in the range of hundredths of millimeters. The precision of measurement (expressed as the measuring uncertainty) should always be an order of magnitude—but at least a factor of five—better than the feature's tolerance.

To follow this rule and therefore provide meaningful measurement results to the manufacturing or

development departments for corrective actions, Kleiner decided on the High Accuracy (HA) version of the Werth VideoCheck. It has a stable mechanical design made of granite with special air bearings, extremely high resolution scales, and design measures to prevent hysteresis. This allows measurement results with an uncertainty of less than one micron, with reproducibility of a few tenths of a micron. The measurement technicians at Kleiner decided on a package of various sensors to equip the machine. They chose the image processing sensor with integrated laser sensor as well as the Nano Focus Probe, NFP, and the patented Werth Fiber Probe, WFP. An additional rotary axis allows the workpiece to be rotated to any position.

### Copper electrodes, punches, dies, embossing dies and inserts

The new high precision 3D metrology at Kleiner helps to optimize the quality of tools and production components. Measuring and checking copper electrodes that are produced by high speed milling requires 20% of the capacity. They are used in the next process step, die sinking, to make the contours and impressions in carbide punches and die inserts. "We determine the dimensions of the additional material needed on the

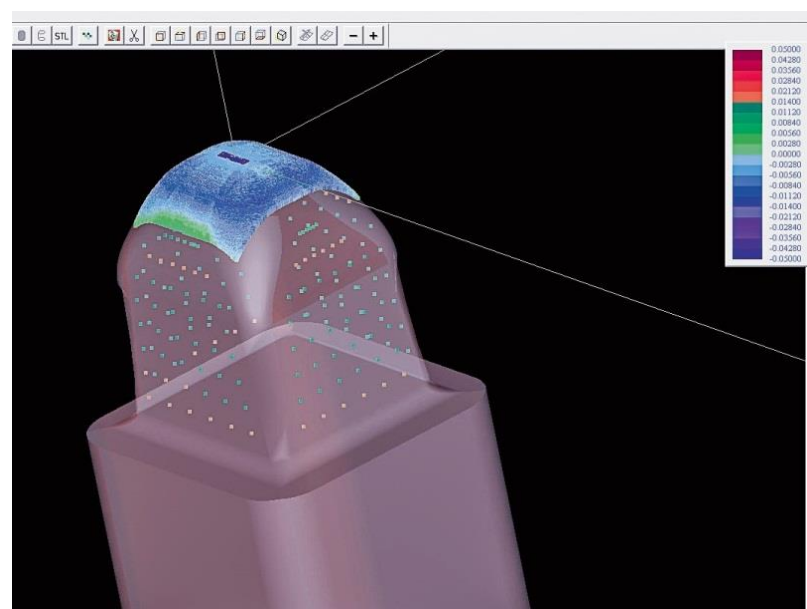

*The embossing die is later measured using the Nano Focus Probe. The results are shown as color code deviations from the CAD model*

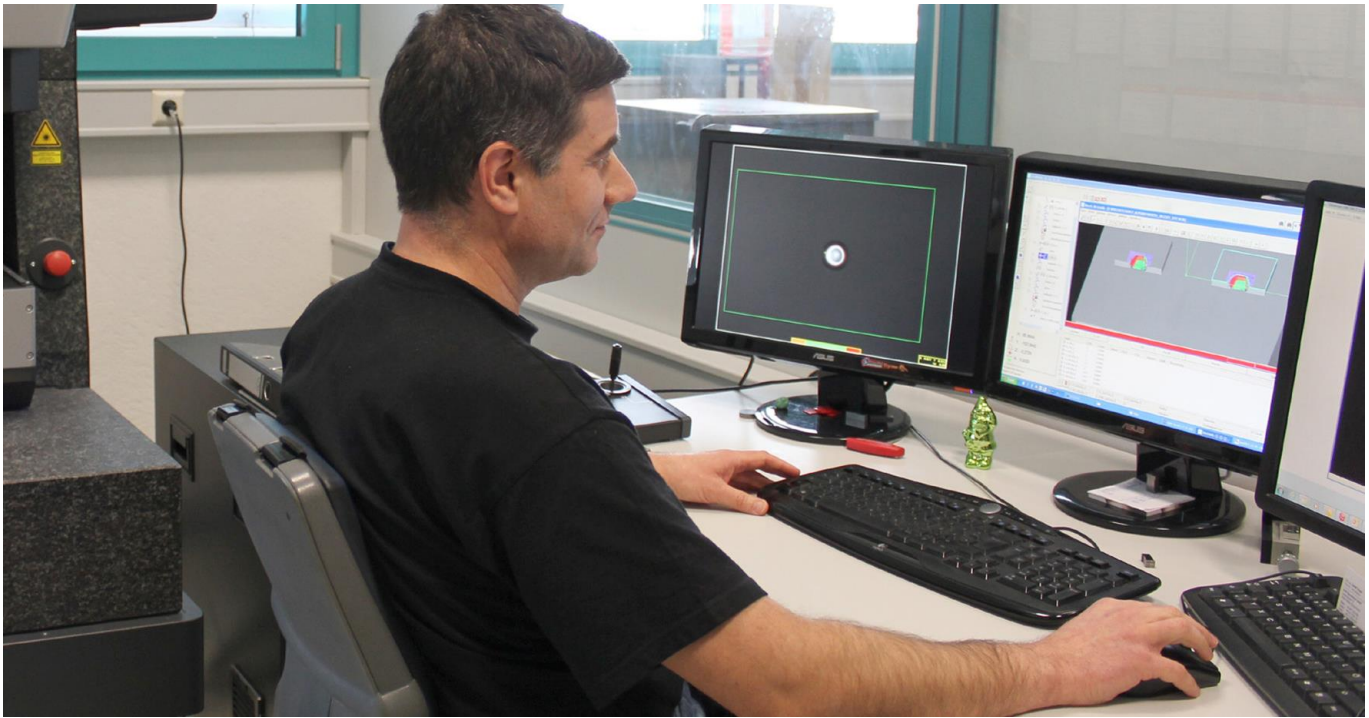

*Measurement technician Adrian Kaubert at work*

electrodes to set the cutting clearance during the die sinking process. The results are used in the die sinking step to determine the electrode position and deflection, so that the eroded shape fits when it is complete," explains measurement technician Adrian Kaubert, who operates the Video Check HA.

About 60% of the machine utilization is for punches and die inserts. If any rework die sinking is necessary, the required contours are determined here. Another 20% of the capacity is needed to check embossing punches and die inserts made of softer materials, which are milled on an HSC machine.

The Nano Focus Probe, NFP, and Werth Fiber Probe WFP are used for precise three dimensional measurements. The NFP is offered exclusively by Werth in coordinate measuring machines and for capturing the shape and fine features of microstructures over large areas on cutting edge radii on tools. Large areas can be measured using the machine axes to reposition the field of view, which is only a few square millimeters in size. By combining multiple images with the precision of the coordinate measuring machine (Werth raster scanning), very large surfaces can be reliably and precisely measured, unlike the alternative stitching methods.

The physical principle of the NFP is confocal microscopy, which ultimately evaluates the intensity of reflected light from bright to dark. The measurement results can differ depending on the material of the measured object. Carbide has a light grained structure and therefore better reflectivity than very smooth materials. On carbide parts, flank surfaces with angles of around 80° can be measured. For high-gloss copper electrodes, the angle is much lower due to the different surface structure.

The measurement range can be flexibly adapted from a few tenths to several square millimeters by using various optics. This means that the punch surfaces at Kleiner in the range of about 2 mm x 3 mm are ideal for this measurement. As Kaubert confirms: "When we capture a punch surface with the NFP, we generate up to 55,000 points, which gives a very high pixel density." As the slope of the surface increases in the edge regions, particularly in the flanks that are perpendicular to the punch surface, the NFP cannot capture any measurement points due to the lack of reflection. This is where we see the benefits of multisensors.

## Fiber Probe Can Even Measure Vertical Surfaces

To obtain data about the side flanks of the punches, the WFP takes over to capture measurement points. This patented microprobe consists of a glass fiber with a probe sphere on the end. The sphere diameter can be as small as 20 µm. In contrast to tactile measurement with a classical probe, the fiber probe operates on a tactile-optical basis. That is, the probe sphere is only there to make contact and its position is captured optically. Because it is attached to a glass fiber, the contact forces are minimal and the probing uncertainty is just a few tenths of a micron. As with a classical probe, the software calculates the corresponding measurement point on the workpiece surface based on the calibrated probe sphere radius.

The measurement points captured by the fiber probe supplement the surface data obtained by the Nano Focus Probe. This makes it possible to generate a complete picture of the quality of the component. All measurement data can be compared to the 3D CAD data using WinWerth measurement software. The contour deviations can be seen at a glance in a color coded deviation plot.

The rotary axis included on the Werth 3D VideoCheck provides additional measurement capabilities. The ability to perform rotary movements means that components can be scanned with the Nano Focus Sensor from any angle. "We have used this many times with very good results. For these punches, however, it is not necessary, as a general rule, to have such high resolution on the flanks. With the Fiber Probe, I can capture the critical points quickly with sufficient resolution and high precision."

As with every Werth coordinate measuring machine, the VideoCheck HA with integrated image processing

sensor is also suitable for two-dimensional measurements. This capability is used at Kleiner whenever capacity is available and Kaubert can support his colleagues by measuring initial production parts.

The use of Werth multisensor technology with sensor data fusion from the WFP and Nano Focus Probe optical sensors has been completely justified and has had a positive effect on the development of precision punched component quality at Kleiner.

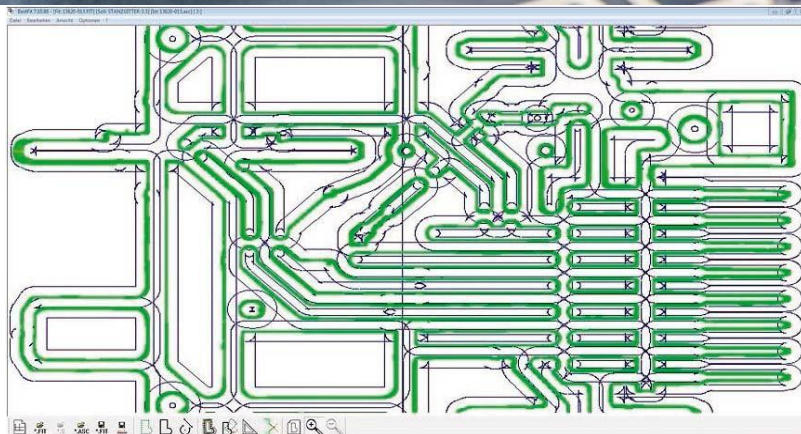
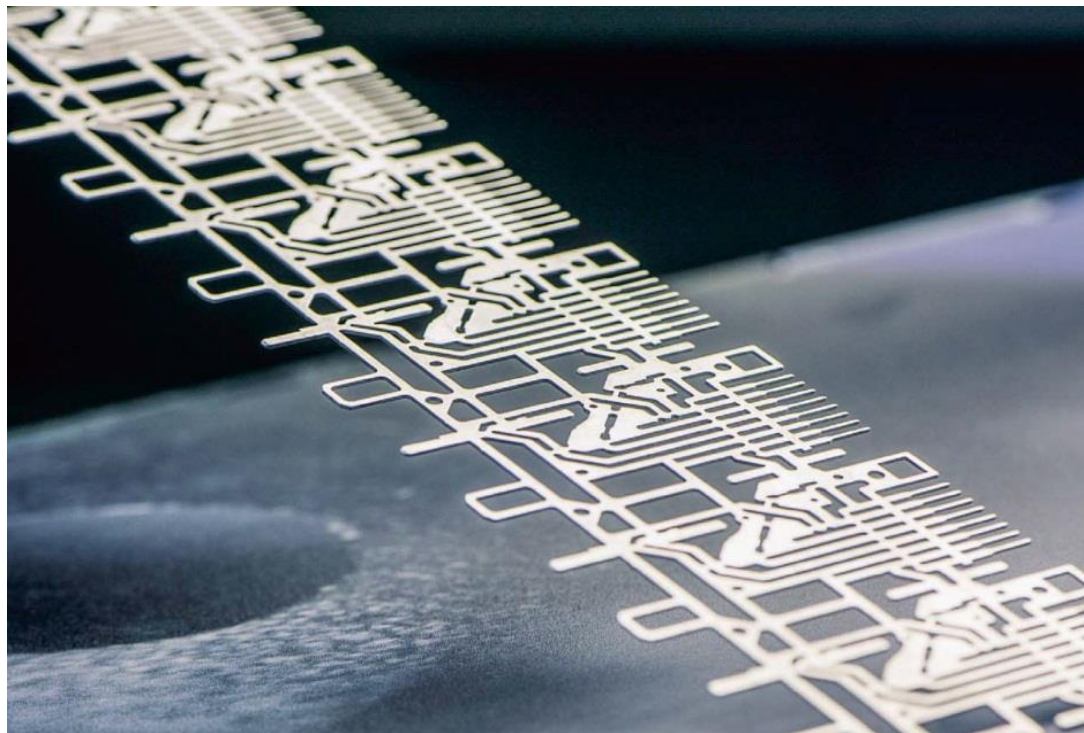

*2D stamped parts are measured and compared with the CAD model*



+++ Newsticker +++ Newsticker +++

Visit our home page

<http://www.werth.de>



Follow us on YouTube



<http://www.youtube.com/c/WerthMesstechnikGmbHGießen>

Werth on Wikipedia



WIKIPEDIA  
Die freie Enzyklopädie

[http://de.wikipedia.org/wiki/Werth\\_Messtechnik](http://de.wikipedia.org/wiki/Werth_Messtechnik)

## Credits

The Multisensor is the in-house newsletter of Werth Messtechnik GmbH  
Siemensstraße 19, 35394 Gießen  
Phone: +49 641 7938-0, Fax: +49 641 7938-719  
[www.werth.de](http://www.werth.de), [mail@werth.de](mailto:mail@werth.de)